

QUALITAS M 4000-6000

Vertical Lathe

APPLICATIONS:

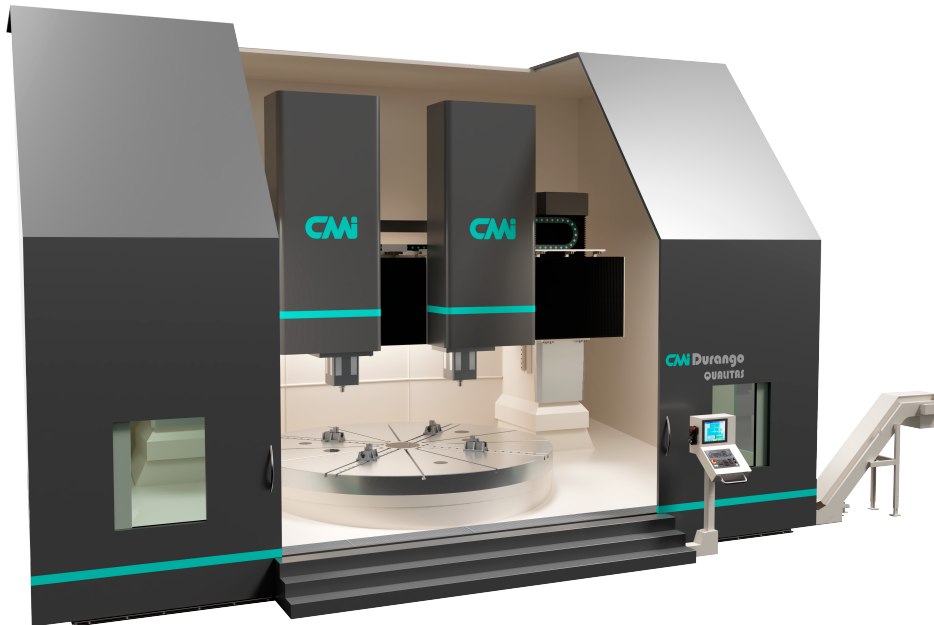

VERTICAL LATHE QUALITAS M Technical Specifications

Max. workpiece diameter (mm)	4500	5000	5500	6100	6600
Chuck diameter (mm)	4000	4500	5000	5500	6000
Max. weight (Tons)	80	80	100	120	150
Max. chuck speed (rpm)	118	100	95	78	75
Turning power (kW)	110	110	110	142	142
Crossrail vertical travel "W" (mm) - (Optional)	1000 / 2000				
Z-axis travel (mm)	1200 / 1500 / 2000				
Ram section (mm)	400x400 (Z-axis: 1200) / 500x500 (Z-axis: 1500 / 2000)				
Milling power (kW)	20 - 65				
Milling speed (rpm)	2000 - 6000				
X-axis feed rate (m/min)	10 / 15				
Z-axis feed rate (m/min)	10 / 15				

Heads



TOOL
HOLDER HEAD



FORK-TYPE
HEAD

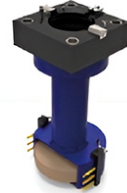

GRINDING
HEAD

Tool warehouse

Number of tools	40 / 60 / 80 / 100
Max. tool weight	20 kg / 35 kg
Tool types	ISO 50 / 60 HSK-63 / 80 / 100... CAPTO C-6 / -8 / -10...

Other accesories and tools

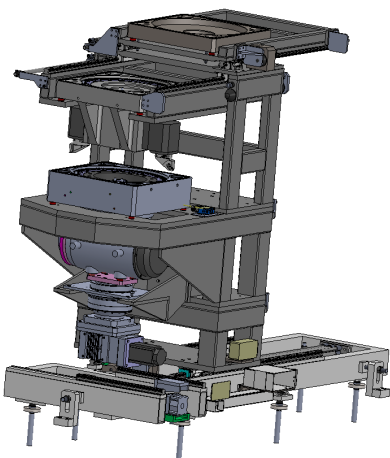

HEAD AND
WORKPIECE CHANGER



PALLET
EXCHANGER

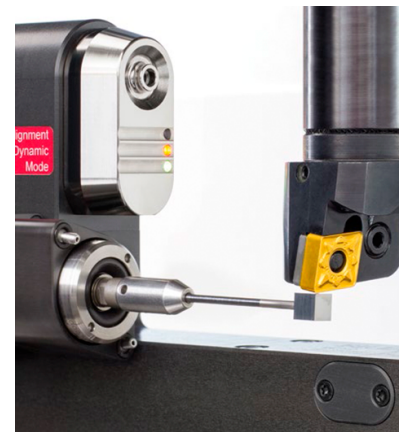

TOOL AND
WORKPIECE PROBE