

QUALITAS S 2200-3500

Multifunction Vertical Lathe

APPLICATIONS:

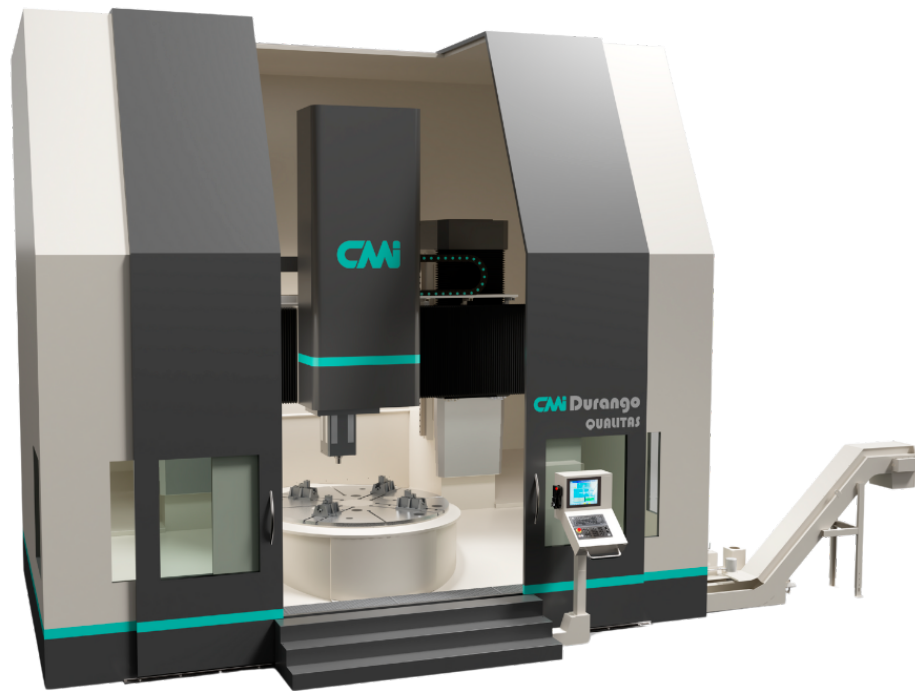

VERTICAL LATHE QUALITAS S Technical specifications

Max. workpiece diameter (mm)	2600	2900	3400	3900
Chuck diameter (mm)	2200	2500	3000	3500
Max. weight (Tons)	25	30	36	36
Max. chuck speed (rpm)	250	225	180	128
Turning power (kW)	74	74	74	74
Crossrail vertical travel "W" (mm) - (Optional)	1000 / 2000			
Z-axis travel (mm)	1200 / 1500 / 2000			
Ram section (mm)	280x280 (Z-axis: 1200) / 350x350 (Z-axis: 1500 / 2000)			
Milling power (kW)	20 - 55			
Milling speed (rpm)	2000 - 6000			
X-axis feed rate (m/min)	10 / 15			
Z-axis feed rate (m/min)	10 / 15			

Heads



TOOL
HOLDER HEAD



FORK-TYPE
HEAD



GRINDING
HEAD

Tool warehouse

Number of tools	40 / 60 / 80 / 100
Max. tool weight	20 kg / 35 kg
Tool types	ISO 50 / 60 HSK-63 / 80 / 100... CAPTO C-6 / -8 / -10...

Other accessories and tools

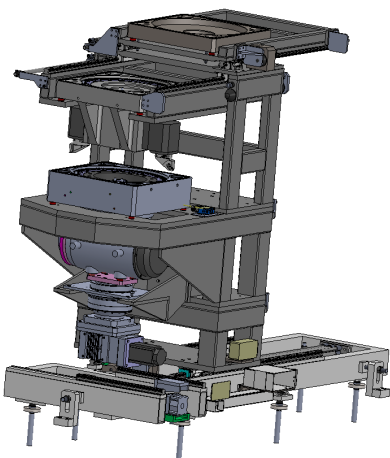

HEAD AND
WORKPIECE CHANGER



PALLET
EXCHANGER

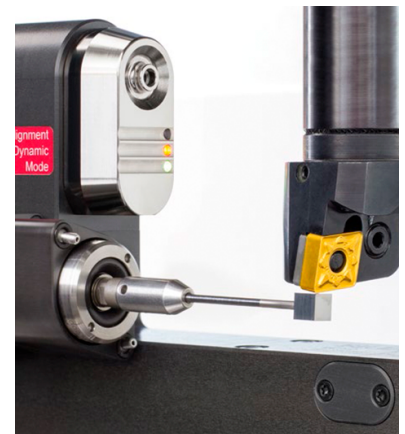

TOOL AND
WORKPIECE PROBE